

## ENGINEER OUT THE RISKS OF THERMOGRAPHY

Description	Open Door Thermography	Hot Spot Monitor
Incident energy exposure	High	None
Special skills & certifications	Required	No
Access to hidden points	No	Yes
Alarm/Indication		
Plant-wide integration		
Inspection frequency	Intermittent	Continuous
Data logging	Manual	Auto

## FREQUENTLY ASKED QUESTIONS

**Q: What is your recommendation on critical connections to monitor?**

*A: We recommend the monitoring points prioritized with load side first followed by line side and field termination connections.*

**Q: Does the HSM have to be integrated into another control system or can it be stand-alone?**

*A: Flexible built-in communication makes plant-wide integration simple. For stand-alone applications, establish a network connection to the device via the GraceSense™ web utility interface to configure, view and retrieve the data.*

**Q: How does the external alarm output work?**

*A: The HSM module has a 2A Normally Open (N.O.) output contact that can be configured to initiate an alarm or horn when any of your program temperature thresholds is exceeded.*

**Q: What do the LEDs on each temperature channel indicate?**

*A: In order to read the proper temperature, there must be adequate fiber power for each channel. A green LED means status OK, while a red LED indicates a failed status. Fail status occurs when the fiber is damaged or is installed with a bend radius less than 0.5”.*

## COMMUNICATION

Easy navigation of GraceSense™ Web Utility interface

allows users to configure the network settings, temperature thresholds, relay outputs and alarm functions. Once the device is configured, user can monitor temperature logs, warning alerts, and download the data for further analysis and trending. **Refer to the support section at [www.GraceSense.com](http://www.GraceSense.com) for more information.**

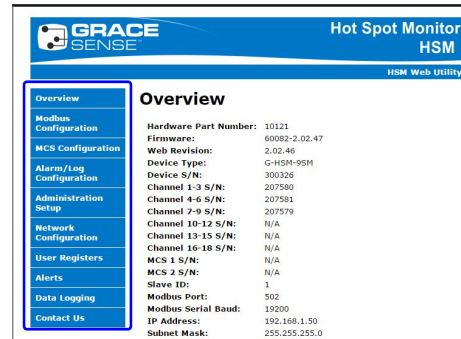

# HOT SPOT MONITOR (HSM)

Find faults before they find you



G-HSM-18K

G-HSM-9SK

**Q: What HMIs and PLC controllers does the HSM interface with?**

*A: Any device that supports Modbus RTU 485, Modbus TCP I/P or EtherNet I/P™ can interface with the HSM.*

**Q: How much data can the HSM module(s) store?**

*A: Each HSM module has 16MB of onboard memory, which is large enough to store 9 years of data logged at every fifteen minute intervals.*

**Q: What precautions should I take when installing the fiber temperature probes in my equipment?**

*A: De-energize the equipment while following your facility's electrical safety procedure. Securely mount the fiber probe assemblies to each monitoring point. Allow a bend radius of 0.5" or greater when routing the fiber; maintain separation between each phase conductors, avoid sharp edges and rough surfaces See HSM-IG-EN for detailed instructions.*

## SAFETY BY DESIGN

- Better Maintenance Planning—Continuous temperature monitoring and alarming device of electrical equipment identifies electrical hot spots before failures and expensive shutdowns occur.
- Simple Field Installation—Non-conductive fiber probes securely piggy-back onto existing bolted connections and potential heat sources such as; busbars, breaker connections, bus ducts, transformers, or any other potential hot spots.
- Any Voltage—Non-conductive technology safely applied to any electrical systems.
- Reduced Risk—Ability to monitor and retrieve temperature data of critical inaccessible connections and their associated alarms safely via GraceSense™ Web Utility Interface, EtherNet I/P™, and MODBUS communication.



### OPERATION

**GraceSense™ Hot Spot Monitor (HSM)** is a non-conductive temperature monitoring and alarming device that identifies potential hot spots and enables user to predict the failures in electrical equipment. Identifying faults before they occur saves money when unplanned outages, service interruptions, and equipment failures are avoided. Plant-wide integration is made simple when the device is connected via MODBUS TCP/IP or EtherNet/IP™ and stand-alone application is made possible with GraceSense™ web interface to configure temperature thresholds, monitoring intervals and relay outputs.

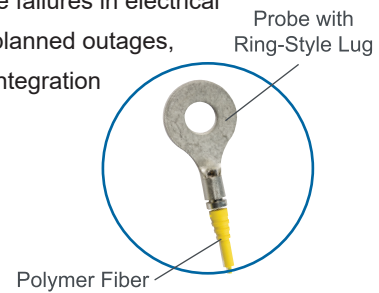

### TECHNICAL SPECIFICATIONS

Varying fiber lengths and lug sizes available. See Accessories section to the right.		
<b>COMPONENT CODE</b>	<b>G-HSM-9SK</b>	<b>G-HSM-18K</b>
<b>Contents</b>	9 Point Temperature Monitoring Module with LCD Display and EtherNet/IP™ Communication, 9 x 10M Probes, 9 x 0.5in Ring-Style Lugs, Probe Tightening Tool, Fiber Trimmer and Quick Start Guide	18 Point Temperature Monitoring Module with EtherNet/IP™ Communication, 18 x 10M Probes, 18 x 0.5in Ring-Style Lugs, Probe Tightening Tool, Fiber Trimmer and Quick Start Guide
<b>Polymer Optical Fiber</b>	10M (kit) standard, 15M sold separately	
<b>Temperature Rating</b>	Probe: -40°C to 120°C (-40°F to 248°F) High-Temperature Probe (sold separately): -40°C to 160°C (-40°F to 320°F)	
	Module: -20°C to 70°C (-4°F to +158°F)	Module: -40°C to 70°C (-40°F to +158°F)
<b>Resolution</b>	1°C (1°F)	
<b>Accuracy</b>	+/- 2°C (+/- 3.5°F)	
<b>Output Relay</b>	Normally Open Contact 2A/250V	
<b>Communication</b>	MODBUS RTU, MODBUS TCP/IP, EtherNet/IP™	
<b>Power Requirements</b>	24VDC (0.12A @ 24VDC, 3 Watt)	
<b>Calibration</b>	No calibration necessary	
<b>Dielectric Characteristics</b>	80kV withstand	
<b>Warranty</b>	5-Year Warranty (register your product online to view detailed warranty information)	

### DIMENSIONS

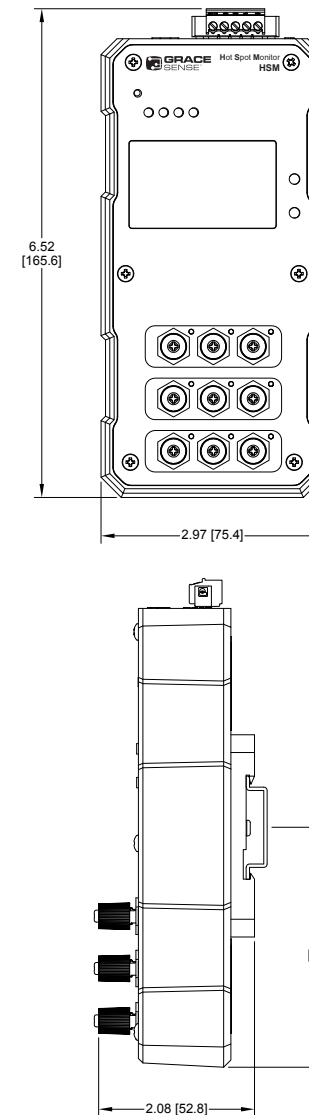

### INSTALLATION

Mount the HSM module on DIN rail inside the low voltage or control compartment. Securely attach the fiber temperature probe to the ring-style connector and mount the probe assembly to existing bolted connections inside of the electrical equipment where heat sources (busbars, lug connections, etc.) or hot spots often originate. Once the bolted connection is made, route the other end of the fiber through the equipment and attach to the HSM module inside the low voltage compartment.



### APPLICATIONS

Current flowing through electrical connections (lugs, screw terminals, circuit breaker stabs, bus-bar joints, etc.) is the main cause for electrical hot spots. Furthermore, some critical hot spots are inaccessible by infrared thermography, and therefore, go unnoticed because an infrared camera cannot obtain an acceptable temperature measurement. The integrity of internal bolted connections, potential hot spots, can be compromised when electrical equipment is subjected to wide load fluctuations or high harmonics. The following are potential applications:

- Low voltage/medium voltage switchgear
- Low voltage/medium voltage MCCs and Drives
- Motors, generators and dry-type transformers
- Load break & Transfer switches
- Bus ducts & busbars connections
- DC switchgear/MCC/Drives
- Large UPS batteries and inverters
- High current junction boxes



### ACCESSORIES (SOLD SEPARATELY)

